

NANDSYNTH

4093 Quad NAND Gate Schmitt Trigger

Based on Nicholas Collins' example in "Handmade Electronic Music" -book

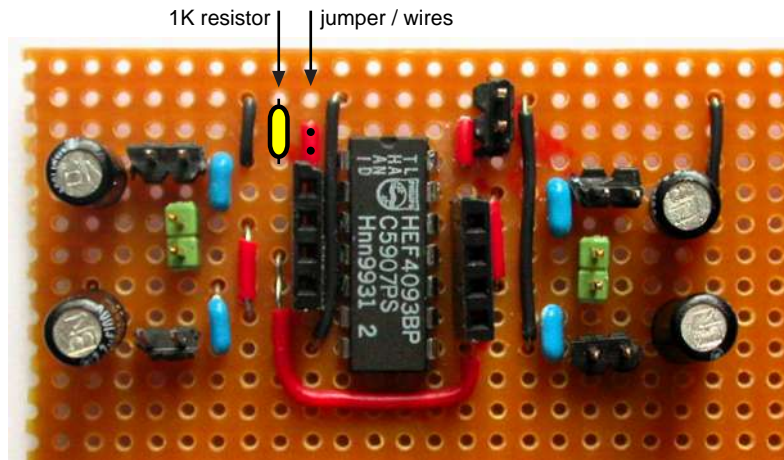

Component side. Mirror the cut points for strip side!

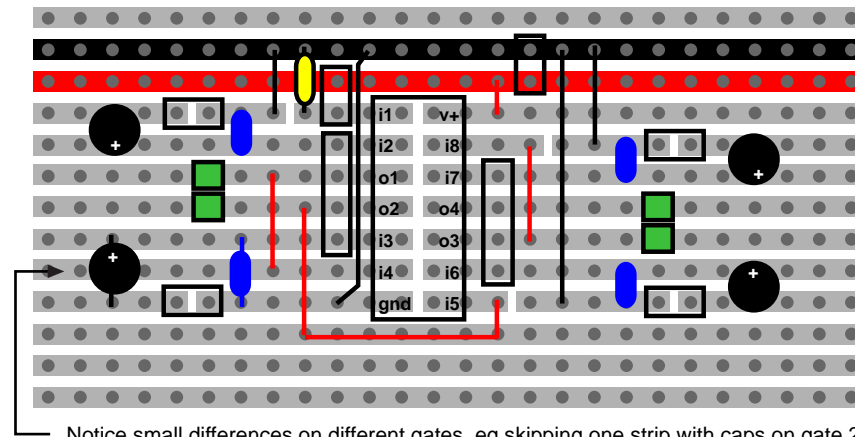

Notice small differences on different gates, eg skipping one strip with caps on gate 2.

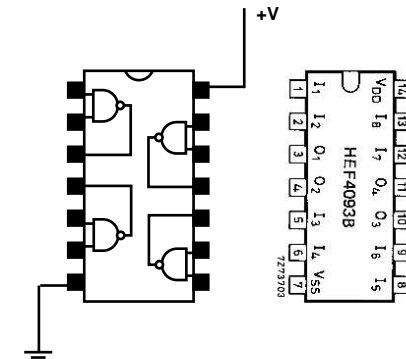
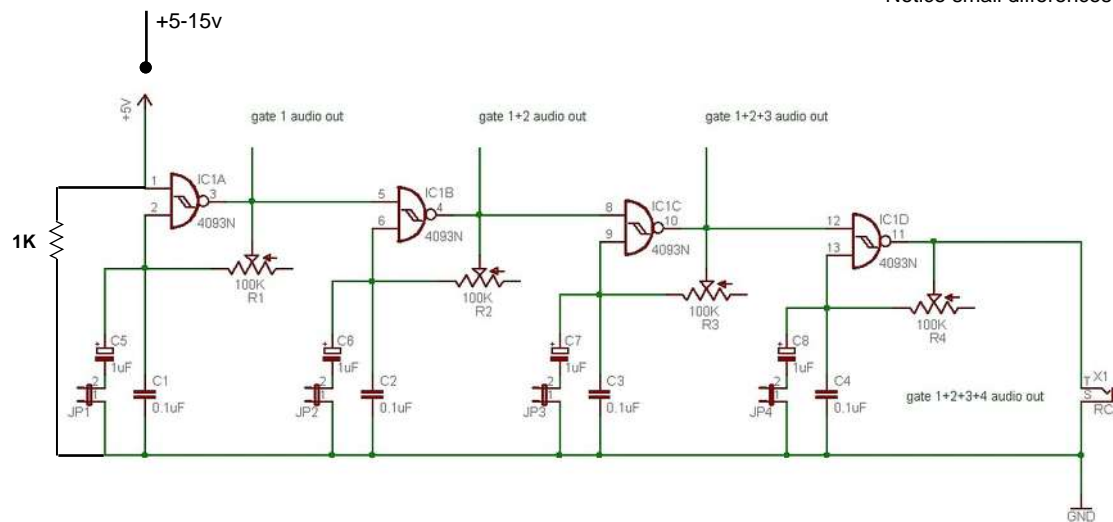

AMP

LM386, Low Voltage Audio Power Amplifier Chip

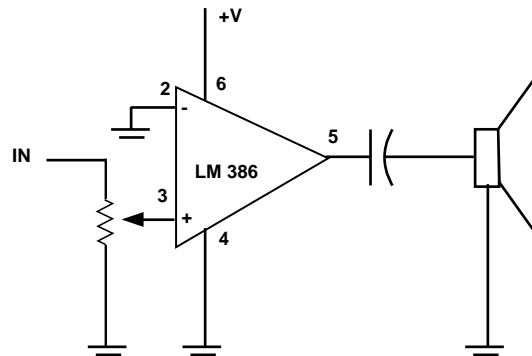
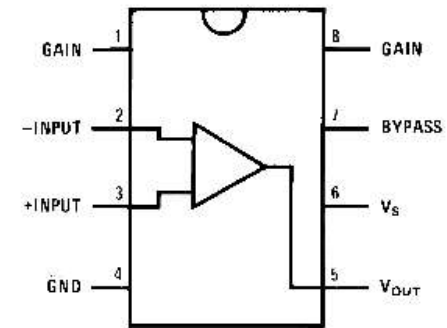
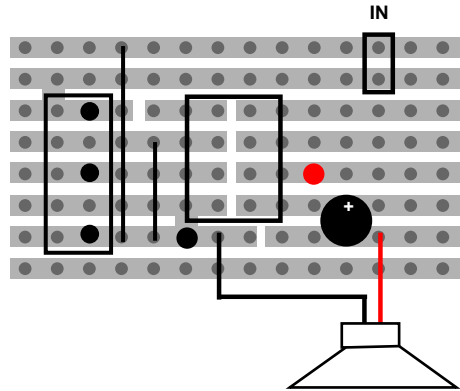
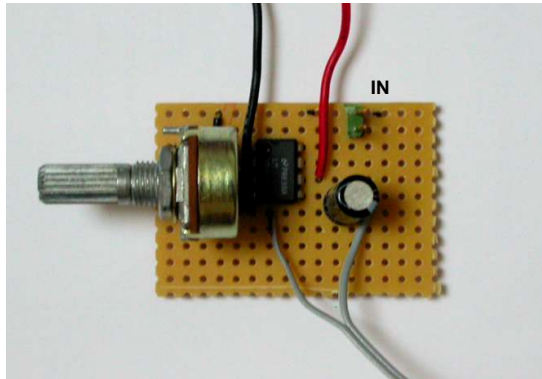

MEMPOT

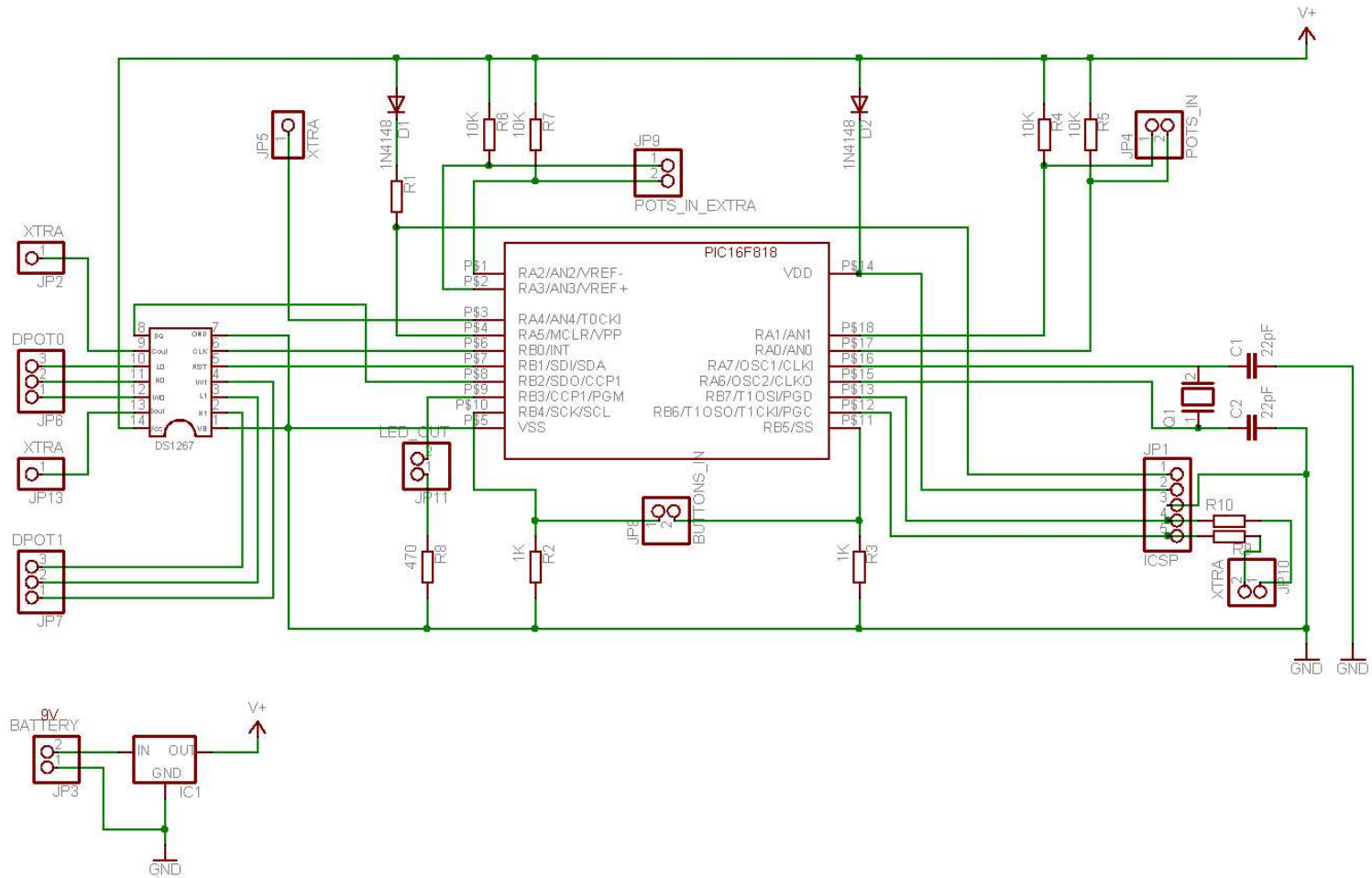

MEMPOT

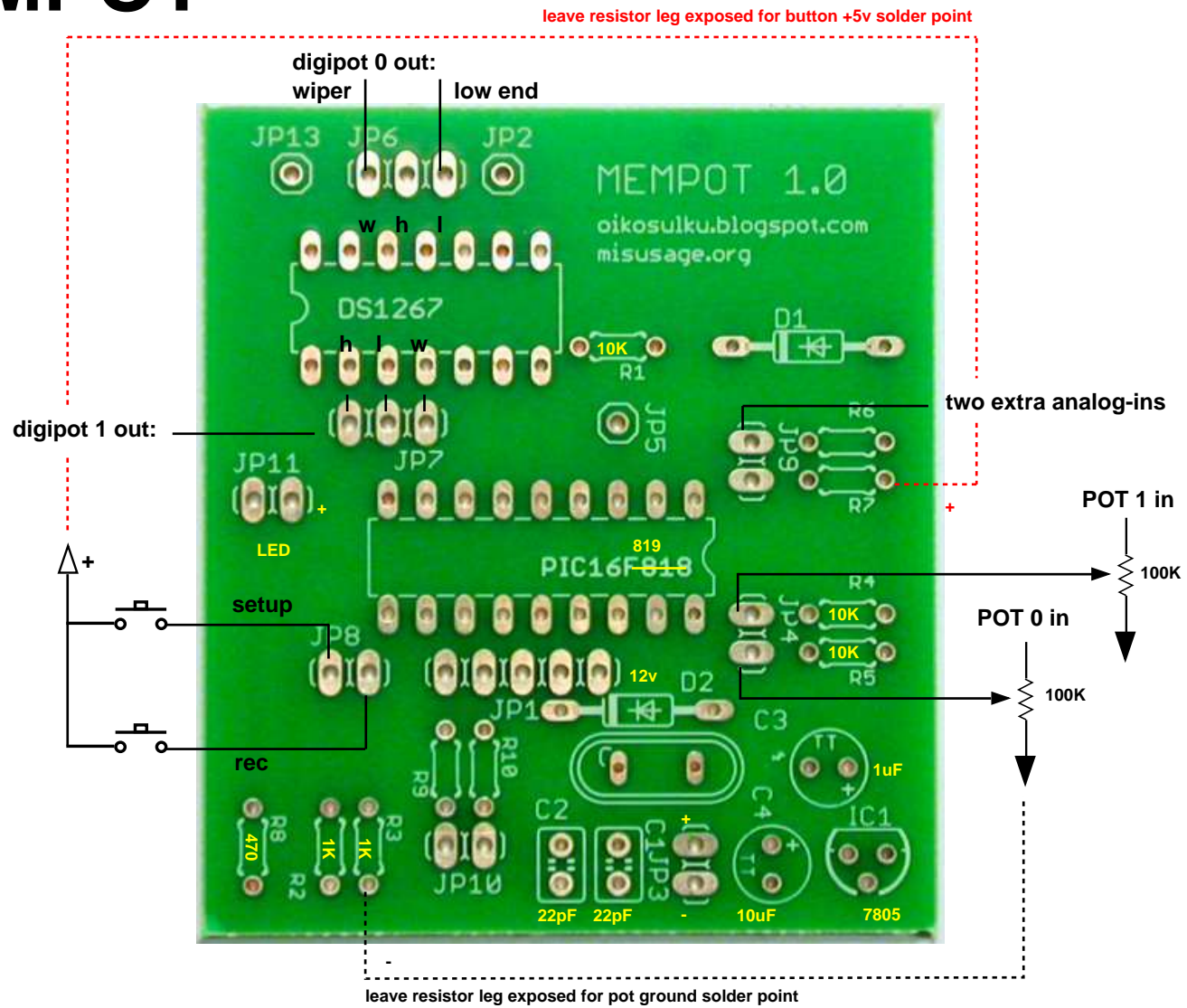

MEMPOT

